

Bailey & Mackey Ltd

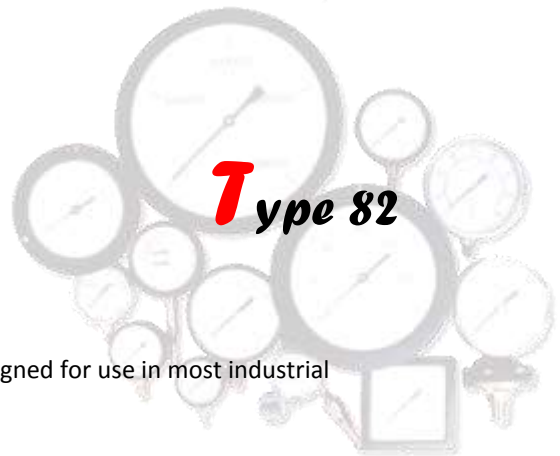

Type 82

Of high quality and robust construction, this range of instruments is designed for use in most industrial applications where the fluid used is not aggressive to copper alloys.

- 50 to 80 mm Diameter
- Direct Mounting
- Centre Back Connection
- Max. Pressure available 700 bar
- 1 bar Vacuum
- Combined Pressure & Vacuum
- Accuracy +/- 1% FSD (50mm dia. +/- 2.5% FSD)
- All Metal Construction
- Full size sensing element
- Enclosure rating IP54



Mechanical Specifications

Materials of Construction

Case	Steel
Bezel	Brass
Window	
Type 82	Instrument Glass
Sensing Element	
Up to 250 mbar	Phosphor Bronze
Above 250 mbar	Steel
Movement	Brass
Connection	Brass
Finish	Black Enamelled

All Bailey & Mackey Pressure Gauges can be adapted to meet the user's application.

e.g. the connecting thread can be modified, the dial can be scaled in any unit and company logo's incorporated, the colour and material of the case and bezel can be changed.

For these and any other modifications please contact our Technical Sales Team.

Type 82 is for use on liquids up to 700 bar and gases up to 25 bar.

Technical Drawings

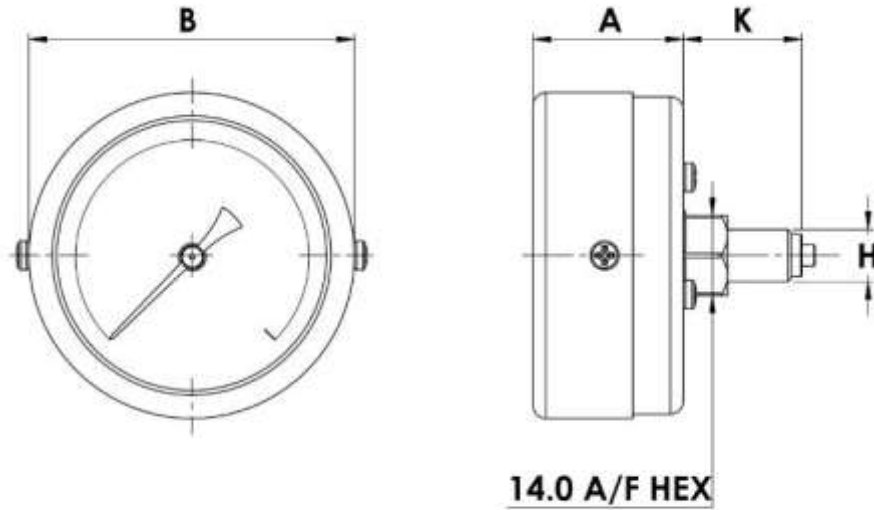

Normal Size	A	B	H	K	Weight
50mm	28.0mm	50.8mm	1/8" BSP	19.0mm	0.127kg
60mm	30.1mm	61.2mm	1/4" BSP	20.6mm	0.182kg
63mm	30.5mm	64.5mm	1/4" BSP	21.6mm	0.19kg
80mm	33.8mm	81.1mm	1/4" BSP	20.6mm	0.25kg