

## Differential Installation



### Installation

Ensure that the differential pressure transducer range, maximum line pressure and materials are correct for application. As the transducer is a delicate instrument it should not be mounted in a position where it is vulnerable to damage.

Connect the high pressure and low pressure connections to the appropriate tapping points. In applications involving flow where differences in line pressure between the two connections are always within the range of the transducer there is no need to fit valves.

In cases where there may be a sudden pressure surge on start-up such as may come from a pump, it is necessary to fit isolating valves on each leg and link the pipes between each valve and the differential pressure transducer by a line with a third valve to use for balancing.

#### Start-up routine with Valves:

1. Run the system with all three valves closed until equilibrium is reached.
2. Open the balancing valve between the high and low pressure connections
3. Open both isolation valves
4. Close the balancing valve
5. The differential pressure transducer will then indicate the pressure differential between the two tapping points.

NOTE: the balancing valve should always be opened before closing the isolating valves when the system is running.

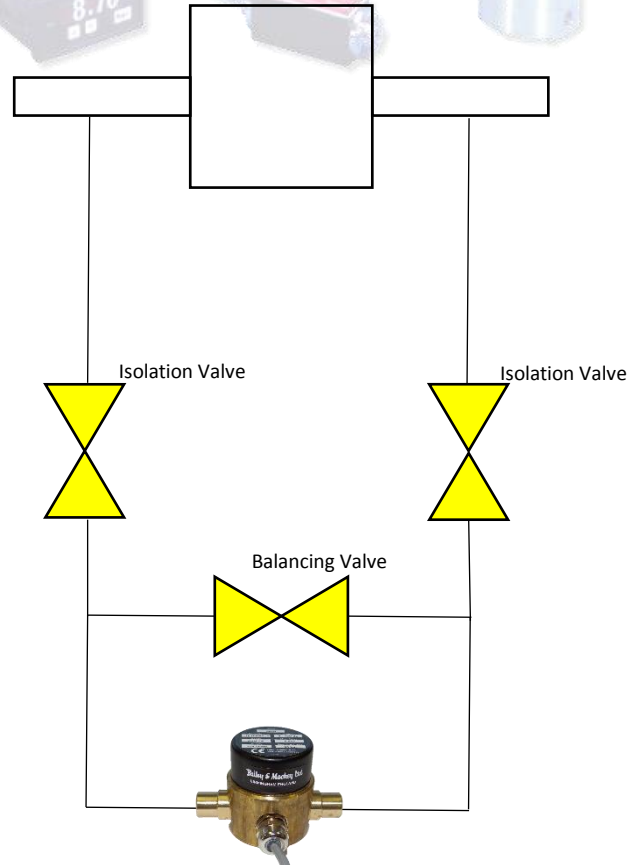

#### Maintenance

No Maintenance is required on these differential pressure transducers.

#### Temperature

Suitable for use over the range 0-80°C. When used with hot water or steam the connections should be made via a 500mm length of copper tube with a coil in it to cool the fluid before it reaches the transducer.