

Bailey & Mackey Ltd

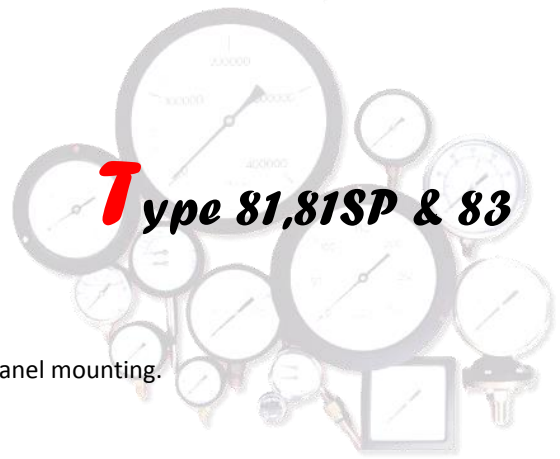

Type 81, 81SP & 83

Of high quality and robust construction, these gauges are intended for panel mounting.

- 60 to 150 mm Diameter
- Panel Mounting with three hole fixing
- Rear Connection
- Ranges available from -1 to 700 bar (Depending on Size)
- Combined Pressure & Vacuum
- Accuracy +/- 1% FSD
- All metal Construction
- Full size sensing Element
- Enclosure rating IP54
- Energy release 100mm dia. and above at rear of case.

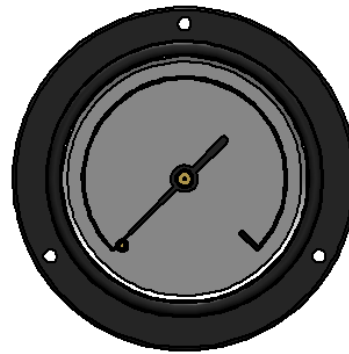

Mechanical Specifications

Materials of Construction

Case

60-100mm	Steel
150mm	Aluminium

Bezel

60-150mm	Steel
----------	-------

Window

Type 81/83	Instrument Glass
Type 81SP	Perspex

Sensing Element

Up to 250 mbar	Phosphor Bronze
Above 250 mbar	Steel

Movement	Brass
-----------------	-------

Connection	Brass
-------------------	-------

Finish	Black Enamelled
---------------	-----------------

Type 81 & 83 are for use on liquids up to 700 bar and gases up to 25 bar

Type 81SP is a full safety pattern Gauge with energy release at the rear and is for use on gases above 25 bar

All Bailey & Mackey Pressure Gauges can be adapted to meet the user's application.

e.g. the connecting thread can be modified, the dial can be scaled in any unit and company logo's incorporated, the colour and material of the case and bezel can be changed.

For these and any other modifications from Contact our Technical Sales Team.

Technical Drawings

63 & 80mm Diameter – Type 83

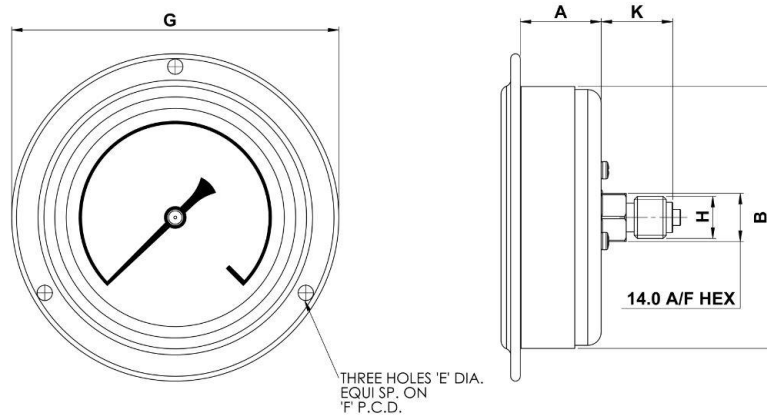

Normal Size	A	B	E	F	G	H	K	Panel Cut-out	Weight
63mm	27.7mm	61.7mm	3.3mm	71.5mm	80.0mm	1/4" BSP	20.6mm	65.0mm	0.28kg
80mm	25.7mm	81.0mm	4.8mm	94.0mm	102.0mm	1/4" BSP	20.6mm	87mm	0.30 kg

100 & 150mm Diameter – Type 81

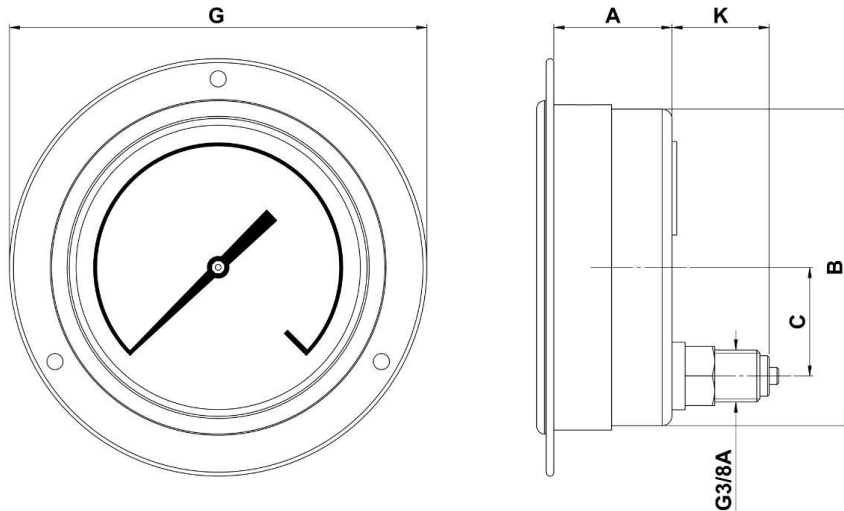

100mm Diameter (SP) – Type 81SP

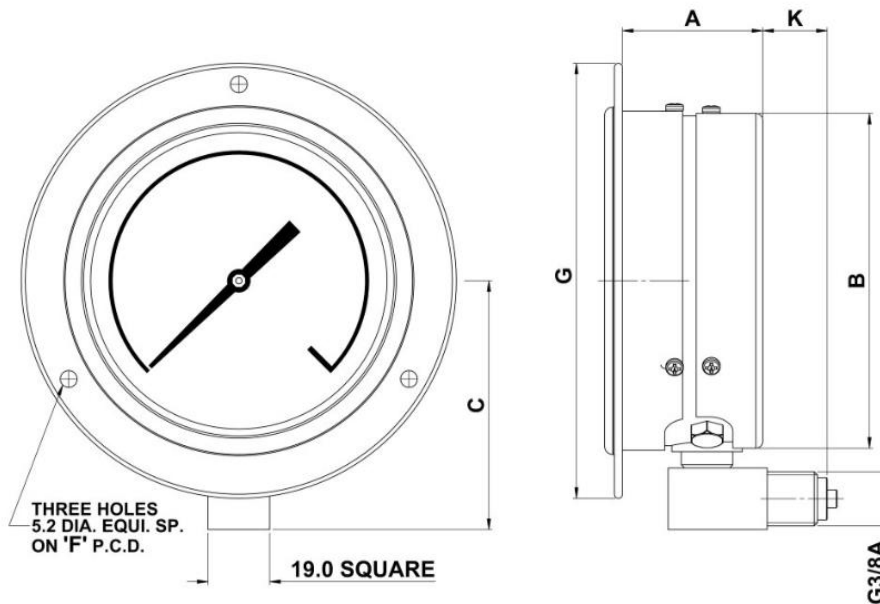

Normal Size	A	B	C	F	G	K	Panel Cut -Out	Weight
100mm	38.2mm	103.5mm	35.0mm	121.0mm	134.0mm	30.5mm	105.0mm	0.8kg
100mm S.P	42.0mm	103.0mm	65.0mm	121.0mm	134.0mm	19.0mm	105.0mm	1.0kg
150mm	48.3mm	163.5mm	56.4mm	175.0mm	175.0mm	27.8mm	165.0mm	1.5kg